

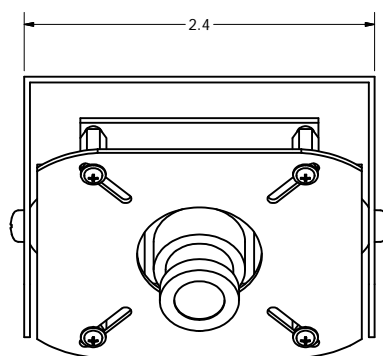

<p>Part Number LV103-0028B-48J</p>	<p>Weight 6.9 lbs (3.14 kg)</p>	
<p>Description LV103 Encl, Dual Power & 2.8mm Lens, 48in pole</p>		<p>http://www.dsmlc.com © 2009 Digital Site Management, L.L.C.</p>

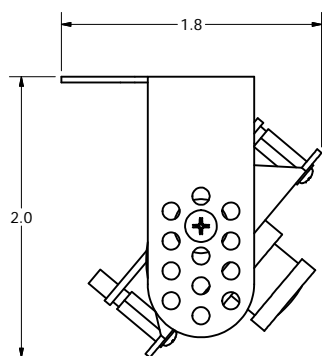
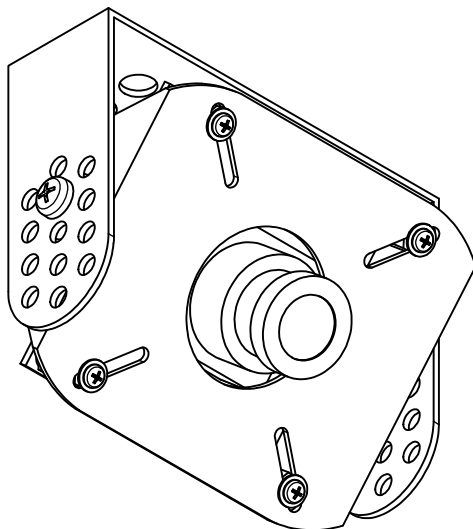

Camera Specifications

Sensor Chip	1/3" SONY HAD High Res. CCD + SONY HQ1 DSP	
Picture Element	NTSC: 768 (H) x 494 (V)	PAL: 752 (H) x 582 (V)
Scanning Frequency	NTSC: 15734 Hz (H) 60 Hz (V)	PAL: 15625 Hz (H) 50 Hz (V)
Resolution	540 TV Lines (580 TVL, F1.0)	
Sensitivity	0.05 Lux (F1.2)	
Synchronizing System	Internal Sync., 2.1 Interlace	
White Balance	Auto	
Gain Control	Yes	
S/N Ratio	52dB	
Gamma	0.45	
Electronic Shutter	Auto [1/60(50)~1/100,000]	
Video Output	1.0Vp-p75Ω	
Lens	2.8mm Fixed Iris Lens	
Backlight Compensation	Auto	
Power Requirement	12 VDC / 125 mA or 24 VAC	
Dimensions	66 (Ø) mm x 50 (H) mm	
Operating Temperature	-10°C to +45°C	
Country of Origin	Taiwan	
Part Number	Weight	
LVC-0028A	0.2 lbs (90 g)	
Description	http://www.dsmlc.com © 2009 Digital Site Management, L.L.C.	
540 TVL, 1/3 CCD, 2.8mm Lens		